



TACÓRA series

Control panels and signalling equipment
with integrated power supply device

090011106



13

Declaration of performance

TA1002: n. 0051 – CPR – 0402
TA1004: n. 0051 – CPR – 0403
TA2000: n. 0051 – CPR – 0401



IT08020000001624



17

Declaration of performance

TA4000: n. 0051 – CPR – 0515

Standards

EN 54-2:1997/A1:2006
EN 54-4:1997/A1:2002/A2:2006



FOREWORD

FOR THE INSTALLER:

Comply strictly with current standards governing the installation of electrical systems and security systems, and with the manufacturer's directions given in the manuals supplied with the products.

Provide the user with full information on using the system installed and on its limitations, pointing out that there are different levels of security performance that will need to suit the user's requirements within the constraints of the specific applicable standards. See that the user looks through the warnings given herein.

FOR THE USER:

Check the system's operation thoroughly at regular intervals, making sure the equipment can be armed and disarmed properly.

Make sure the system receives proper routine maintenance, employing the services of specialist personnel who meet the requirements prescribed by current regulations.

Ask your installer to check that the system suits changing operating conditions (e.g. changes in the extent of the areas to be protected, change in access methods, etc...).

This device has been designed, built and tested with the utmost care and attention, adopting test and inspection procedures in accordance with current legislation. Full compliance of the working specifications is only achieved in the event the device is used solely for its intended purpose, namely:

Control panels and signalling equipment with integrated power supply device

The device is not intended for any use other than the above and hence its correct functioning in such cases cannot be assured.

Consequently, any use of the manual in your possession for any purpose other than those for which it was compiled - namely for the purpose of explaining the product's technical features and operating procedures - is strictly prohibited.

Production processes are closely monitored in order to prevent faults and malfunctions. However, the componentry adopted is subject to an extremely modest percentage of faults, which is nonetheless the case with any electronic or mechanical product.

Given the intended use of this item (protection of property and people), we invite you to adapt the level of protection offered by the system to suit the actual situation of risk (allowing for the possibility of impaired system operation due to faults or other problems), while reminding you that there are specific standards for the design and production of systems intended for this kind of application.

We hereby advise you (the system's operator) to see that the system receives regular routine maintenance, at least in accordance with the provisions of current legislation, and also check on as regular a basis as the risk involved requires that the system in question is operating properly, with particular reference to the control unit, sensors, sounders, dialler(s) and any other device connected. You must let the installer know how well the system seems to be operating, based on the results of periodic checks, without delay.

Work involved in the design, installation and maintenance of systems incorporating this product should be performed only by personnel with suitable skills and knowledge required to work safely so as to prevent any accidents. It is vital that systems be installed in accordance with current legislation. The internal parts of certain equipment are connected to the mains and therefore there is a risk of electrocution when maintenance work is performed inside without first disconnecting the primary and emergency power supplies. Certain products include batteries, rechargeable or otherwise, as an emergency backup power supply. If connected incorrectly, they may cause damage to the product or property, and may endanger the operator (explosion and fire).

EU DECLARATION OF CONFORMITY

The product complies with current European EMC and LVD directives. When using the GSM dialler, the product also complies with EN 54-21:2006. The full text of the EU declaration of conformity is available at the following Internet address: www.elmospa.com – registration is quick and easy.

DISPOSAL INSTRUCTIONS - INFORMATION FOR THE USER



IT08020000001624

In accordance with Directive 2012/19/EU on waste electrical and electronic equipment (WEEE), please be advised that the EEE was placed on the market after 13 August 2005 and must be disposed of separately from normal household waste.

This product needs batteries for correct functioning. Exhausted batteries have to be delivered to dumping grounds authorized for battery collection. The materials used for this product are very harmful and polluting if dispersed in the environment.



1. GENERAL FUNCTIONING

A fire control panel uses input and output devices, each assigned to a zone (a part of the protected area, defined by UNI standards). A **conventional line** can connect several input devices or several output devices, all belonging to the same zone. An **analogue-addressable loop** can connect input and output devices, even belonging to different zones.

Each model in the TACÓRA fire panel series can manage a different number of lines or loops:

- TA1002 - 2 conventional lines + 1 MCP (Manual Call Point conventional line).
- TA1004 - 4 conventional lines + 1 MCP.
- TA2000 - 4 conventional lines + 1 MCP + compatible with the following optional boards:
 - TAEXP10 - optional board with 8 additional conventional lines;
 - 1 analogue-addressable loop module.
- TA4000 - 4 conventional lines + 1 MCP + compatible with 2 × optional loop modules.

All models are also compatible with the following optional boards:

- TAREL24 - 4 extra relay outputs.
- EXTING - for controlling automatic fire extinguishers (only compatible with TACÓRA boards v.3 or higher).
- MDGSME + GSMACI antenna kit - for remote assistance (monitoring, control and configuration) on TACÓRA boards v.5.2 or higher and for sending alert messages to a phone number, via GSM.
- MD4GE + ANT4GTA antenna kit - for remote assistance (monitoring, control and configuration) on TACÓRA boards v.5.3.1 or higher and for sending alert messages to a phone number, via LTE 4G.
- MDLAN - for remote assistance via Ethernet (only compatible with TACÓRA boards v.5.2 or higher, remote control is not EN54-compliant).

The following images show the position of the power supply unit and of the main and optional boards.

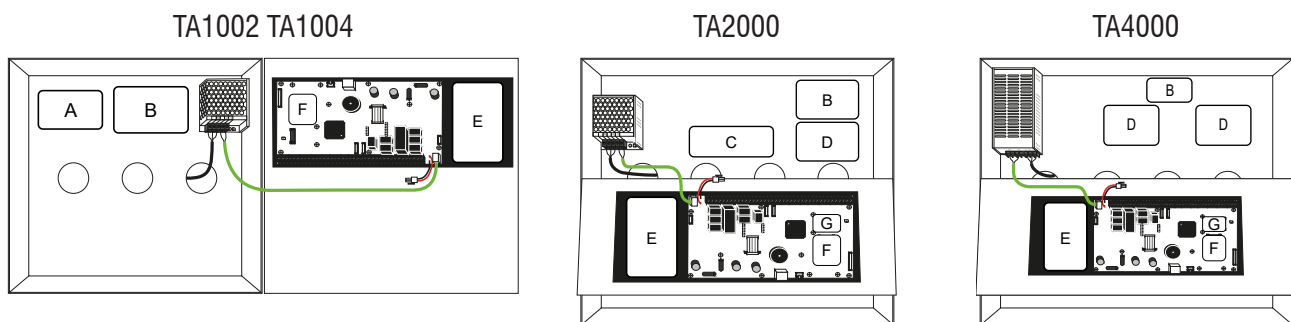

- A. FXLAN2
- B. TAREL24
- C. TAEXP10
- D. TAEXP20 or TALOOP
- E. EXTING
- F. MDGSME/MD4GE
- G. MDLAN

This guide will teach you to install and program a generic fire detection system based on a TACÓRA control panel. The technical and programming manual and the manuals specific to each device go into more details.

2. POSITIONING THE CONTROL PANEL

Choose an accessible position, for the front panel has a display and several buttons used during programming and to manage alerts. Remotization with max. 2 TAREPEATER keyboards is detailed in the technical and programming manual.

Choose a position that makes it possible to reach each device in the system while complying to the max lengths for line and loop cables (see the table and keep in mind that the loop needs to start and end at the control panel).

Cable section	Max cable length		Max resistance	Max capacitance
	Loop	Conventional line		
2 × 0.5 mm ²	500 m	800 m	18±10% Ω/km (loop) 65 Ω (conventional)	85±10% pF/m
2 × 1 mm ²	1000 m	1500 m		
2 × 1.5 mm ²	1500 m	2000 m		
2 × 2.5 mm ²	2000 m	-		

Use shielded, twisted, flame-resistant cables with low smoke emissions and no halogens only. The cables must resist to fire for at least 30 minutes and should comply to all legal standards.

The panel has to be reached by a well-grounded 220 V mains cable, equipped with an easily accessible bipolar magnetothermic switch, a device for disturbance suppression and eventually a saturated iron voltage stabilizer (all installed outside the panel's metal box).

Deploy all cables so that they can enter the control panel from the holes on its back.



3. INSTALLATION

1. Choose a wall that is able to hold the weight of the control panel.
2. Choose the wall plug (and screws) size and type according to the wall material.
3. Drill the wall where shown in the following diagrams and put the wall plugs in place. Measurements are in mm.

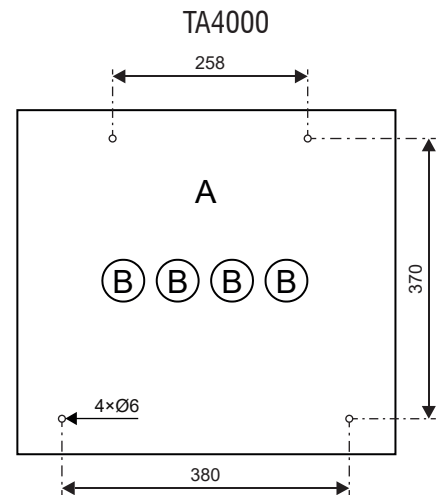
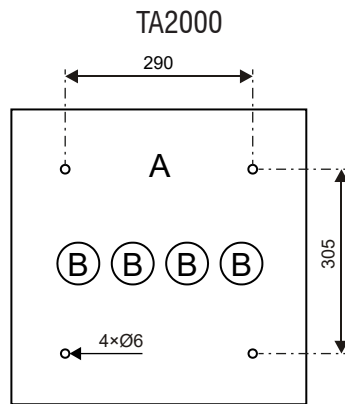
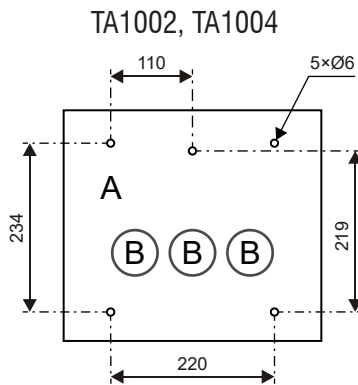

A = bottom of the control unit
B = cable feed holes

4. Loosen the fixing screws at the corners of the control panel's front
5. **TA1002 and TA1004:** open the cover. **TA2000 and TA4000:** remove the cover (pay attention to the yellow and green cable that grounds the cover) and set it aside. Remove the screws at the top of the display flap and tilt it down.

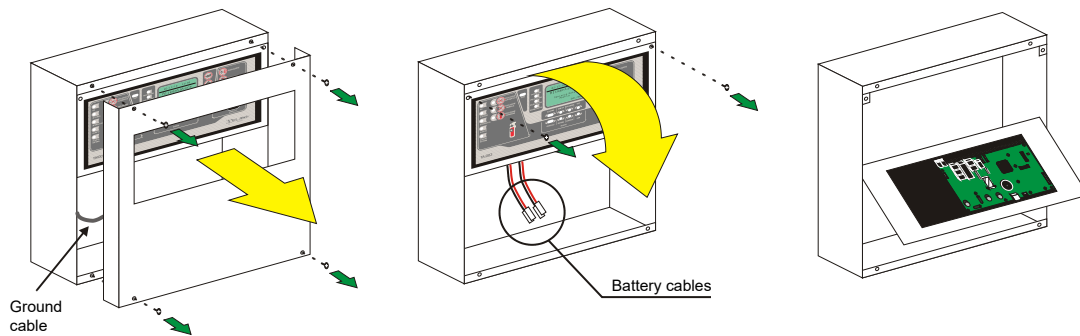

6. Place the box against the wall, feeding the cables through the holes in the back. The mains cable shall enter through its own hole.



WARNING: to prevent damaging the electronic components, generating false alarms or suffering a shock, unplug the other end of the mains cable during the hardware installation and servicing operations.

7. Screw the fire control panel to the wall.
8. Wire the power supply unit as shown in the frame in the next page, winding the main cable wires four times around the FT25 toroid.
9. Fix any optional boards and modules in their place, where shown in chapter 1, using the plastic spacers or the screws and washers included in their package.
10. Wire the lines and the loop, both to the control panel and to the devices, as detailed in the following chapters.
11. Connect to each device the additional power supplies, the remote LEDs, the monitoring circuits and any other accessory or mandatory connection detailed in the manuals for that device.
12. Make sure that every cable shield is connected to a ground terminal. Some boards have their own ground terminal, all other cables should be grounded at the common screw terminal that is already connected to the bottom of the metallic box. Except for the loop cable, which screen is connected to the ground at both ends, all other cables have to be grounded at a single point.
13. Place two 12 V rechargeable batteries with proper amperage inside the housing (7 Ah for TA1002 and TA1004, 7 or 18 Ah for TA2000, 26 Ah for TA4000). Place a NTC temperature sensor on each and wire them to the main board. Paying attention to the polarity, connect each battery to one of the two couples of battery cables shown above.
14. Clean the electronic boards from any copper pieces resulting from wire trimming.
15. Close the control unit, following points 5 and 4 in reverse, then plug the mains cable to the AC 230 V source.
16. Program the control panel, either from the front panel or by connecting a PC with the BROWSERONE software. (A mod. CP8/SER2 cable or FW v.5 and a Mini-B/USB cable is needed for the connection. BROWSERONE and its manual can be downloaded from the



www.elmospa.com website. An Internet connection is needed to download software and firmware updates.)

3.1 Main board: connectors and jumpers

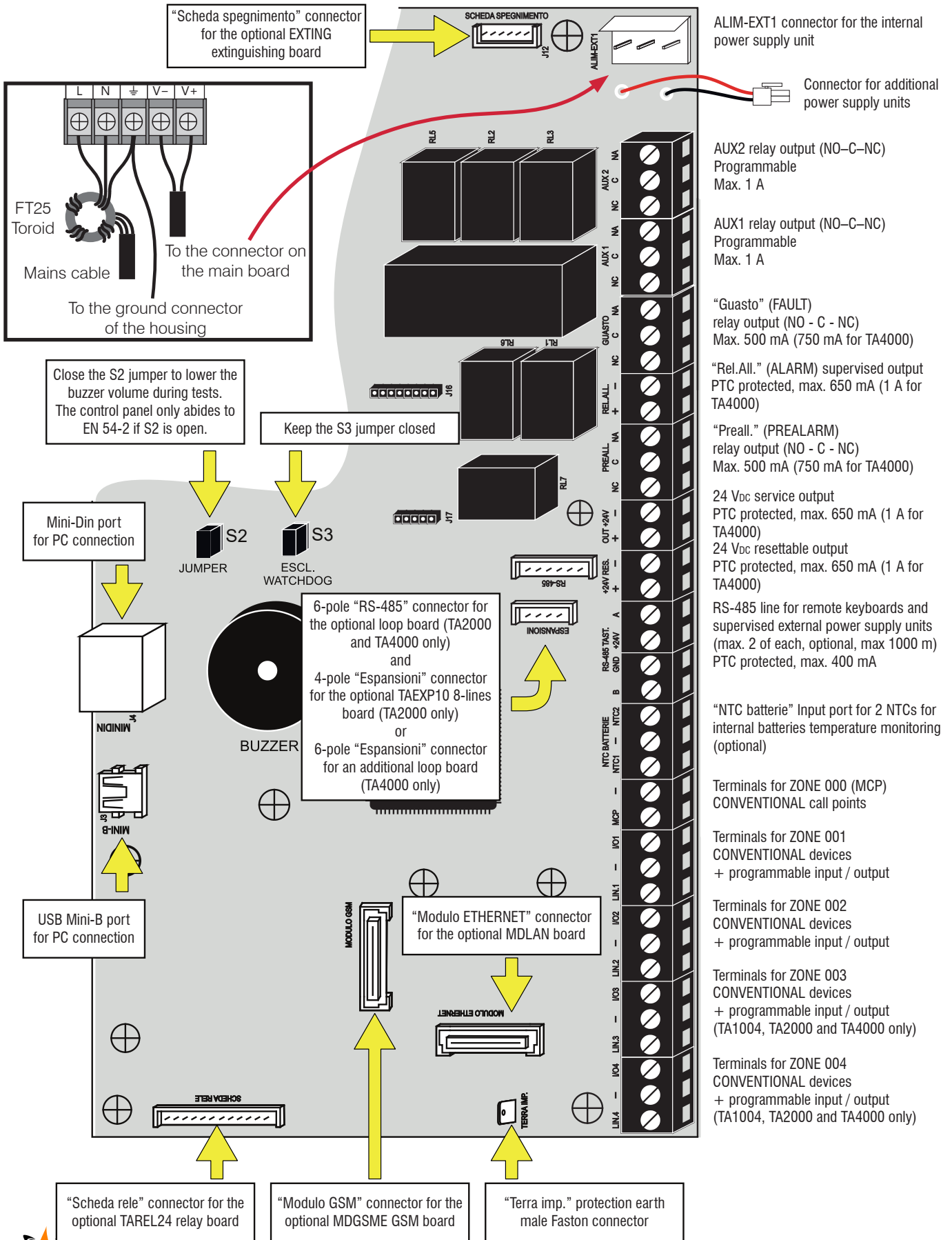



3.2 Wiring

Some of the lines are supervised, thus feature an end-of-line 4700 Ω resistor.

In unused supervised lines, wire the end-of-line resistor directly at the board terminals, to avoid generating line faults. When instructed to wire cable shields together, always use a terminal that is insulated from the rest of the system. Each network of cable shields must be connected to the earth terminal of the control unit in a single point (do not create loops on the earth circuit). Also avoid connecting the earth circuit with the GND or negative terminals. The diagrams in this chapter represent the case of a single device with a rectangular grey background.

3.2.1 Input lines

In order to comply with the EN 54-2 standard, install max 32 devices per conventional line.

3.2.1.1 MCP line (zone 0)

Example: BRVEN series manual call points

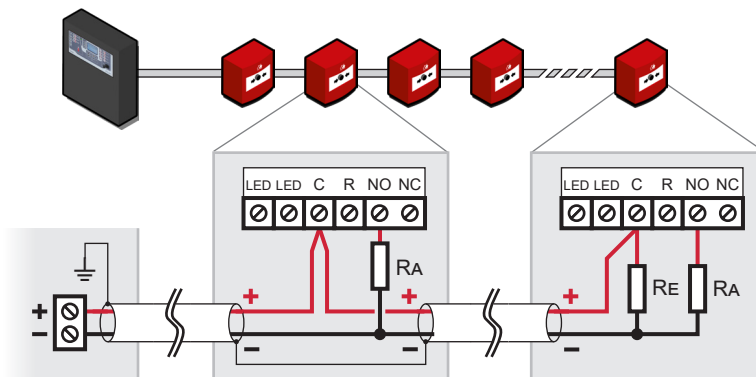

R_A = 1 k Ω alarm resistor. The technical manual details an alternative wiring that does not need this resistor
 R_E = 4700 Ω end-of-line resistor, mounted inside the case of the last device of the line (max 32 devices)

3.2.1.2 Conventional lines (zones 1 to 4, plus zones 5 to 12 on the TAEXP10 board)

- Conventional line terminals can be used to manage a conventional line (terminals "LIN#" and "-", detailed here) and/or as a programmable input/output (terminals "-" and "I/O#", detailed in the technical and programming manual).
- Any conventional line can be used as a MCP line. Follow the previous diagram, using the "LIN#" terminal instead of "MCP".

Example: SN1xxC conventional detectors

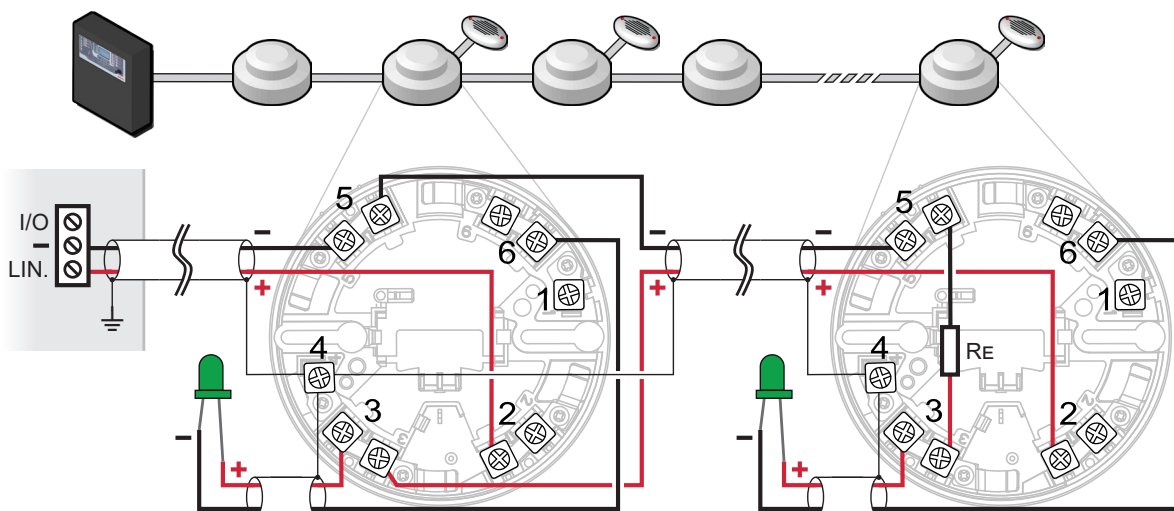

R_E = 4700 Ω end-of-line resistor, mounted inside the case of the last device of the line (max 32 devices)

The remote LED is mandatory if the LEDs on the detector are not visible (e.g. if the detector is in a false ceiling or under a raised floor).



3.2.2 Output lines

In order to comply with the EN 54-2 standard, unsupervised outputs shall only be connected to devices protected against cuts and short circuits (type C, E, G or J). Therefore, do not connect alarm devices, automatic systems or devices for the transmission of fire alarm and fault events to unsupervised outputs.

3.2.2.1 OUT +24V line

This line is used to feed the devices that need it. Connect the powered devices in parallel.

3.2.2.2 +24V RES. line

This output works like the OUT +24V output but it stops providing power to the connected devices for a few seconds at each control panel reset. Use it to feed the devices that can be reset by interrupting their power source for a set time (e.g. some smoke barriers).

3.2.2.3 Relay lines (prealarm, fault, AUX1, AUX2 and TAREL24 outputs)

These are all unsupervised relay terminals.

Almost every device is connected to the NC side of the relay, so that the device also activates if the line is cut.

This includes acoustic signalling on the “guasto” (fault) line, which relay is active by default. All other relays are programmable.

Example: connection of electromagnetic door retainers to an NC relay with internal or external power supply

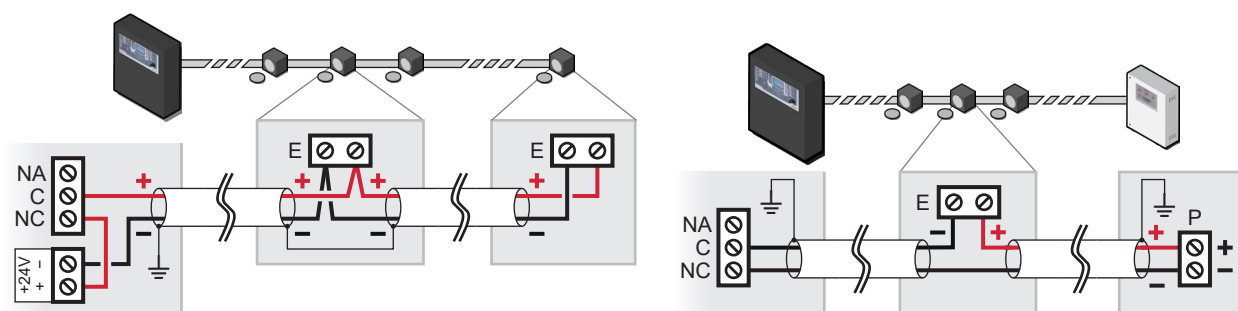

E = electromagnetic door retainer

P = external power supply unit

The wirings for circuits connected to the NA (normally open) side of the relay are detailed in the technical manual.

3.2.2.4 Alarm line

The alarm output line is supervised.

As with supervised inputs, a voltage must be constantly applied to the terminals: the value of the resulting current makes it possible to infer if the line has been cut or if it is shorted.

In order to prevent this supervision voltage from activating the connected devices, the supervision voltage is negative (opposite polarity than the silk print) and diodes prevent negative voltages from reaching the connected devices.

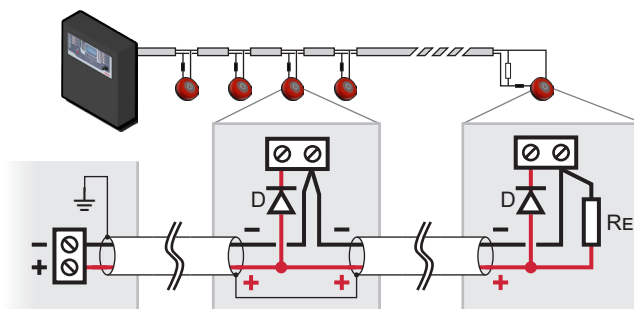

D = 1N4001 or equivalent diode (e.g. 1N4007)

RE = 4700 Ω end-of-line resistor, mounted inside the case of the last device of the line



3.3 Connection of the optional boards

3.3.1 EXTING

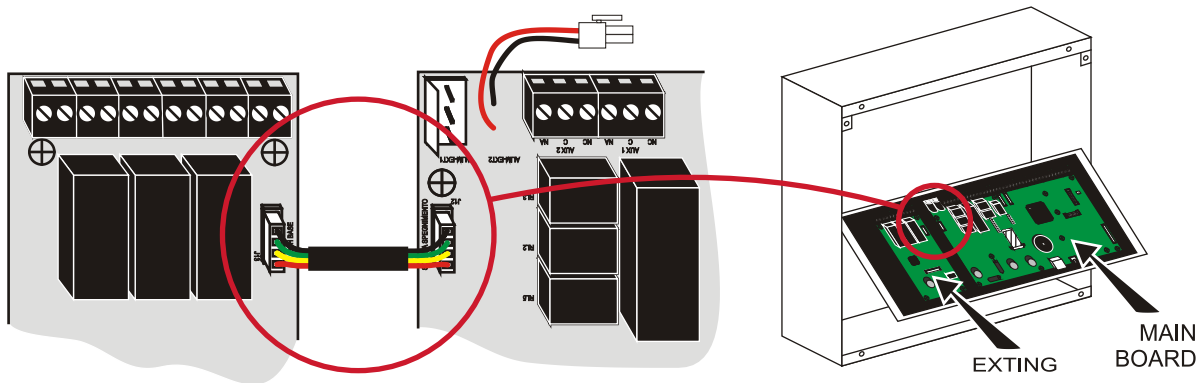

1. Use four self-tapping screws to fix EXTING to the holes in the position shown above.
2. Use the provided 4-wire cable to connect EXTING's "RS-485" connector to the "Espansione" connector on the main board.
3. Stick the provided CPR label next to the one of the control panel, on the right side of the container.

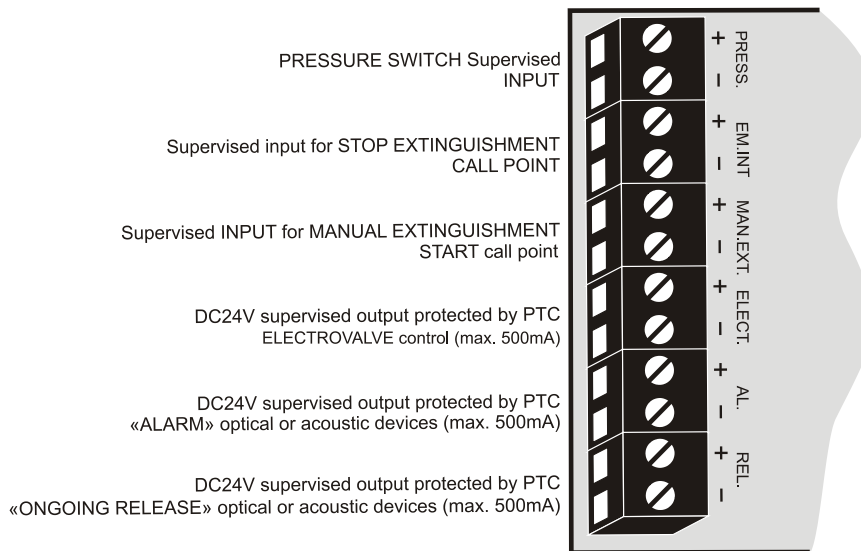

3.3.1.1 Call point lines

The yellow call points connected to the MAN.EXT terminals are used to demand the emission of the extinguishing agent. The emission will happen after an internal countdown.

The blue call points connected to the EM.INT terminals are used to pause this countdown for as long as the call point is being pressed. To cancel the request or to stop an ongoing emission, use the level 3 menu of the control unit.

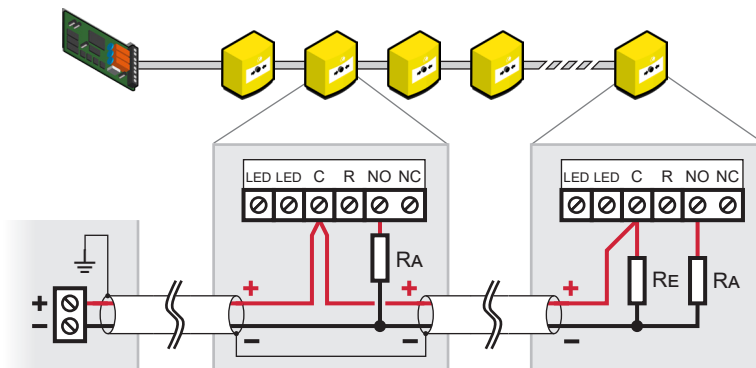

$R_A = 18\text{ k}\Omega$ alarm resistor

$R_E = 47\text{ k}\Omega$ end-of-line resistor, mounted inside the case of the last device of the line (max 32 devices)



3.3.1.2 Pressure input

This input is used to monitor the pressure (thus the flux of the extinguishing agent) inside the pipes of the extinguishment system.

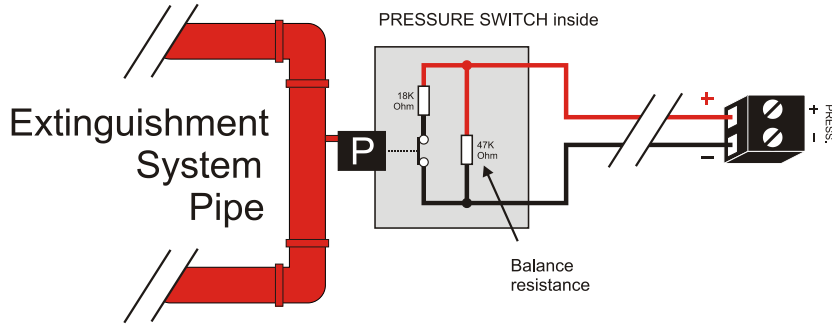

3.3.1.3 Electro-valve output

The ELECT. output is used to command the electro-valves that activate the extinguishment.

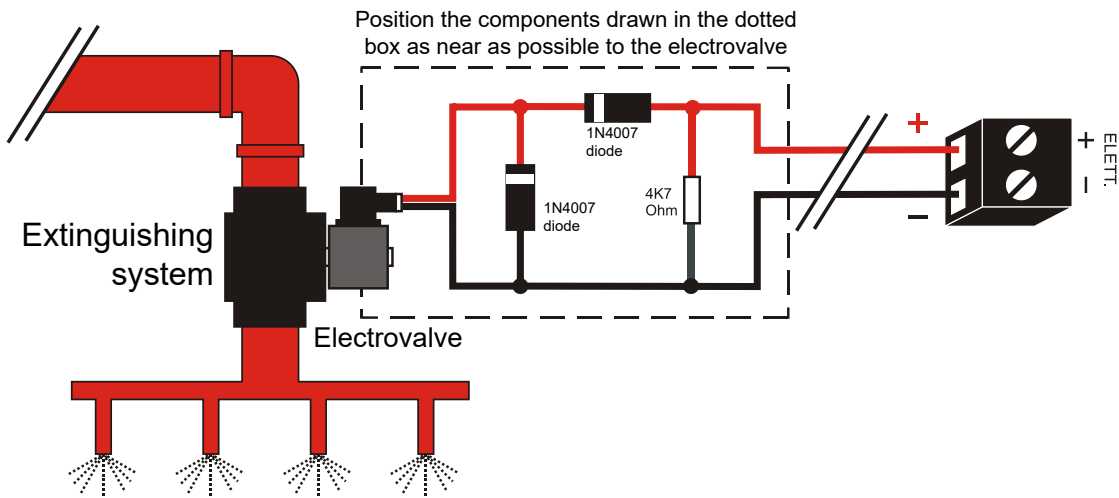

3.3.1.4 Alert outputs

The alarm and ongoing release output lines work exactly the same as the alarm and prealarm output lines for the main board. In case of delay, the AL. output activates as soon as EXTING is alerted, the ELECTR. and REL. output activate after the delay.

3.3.2 TAREL24

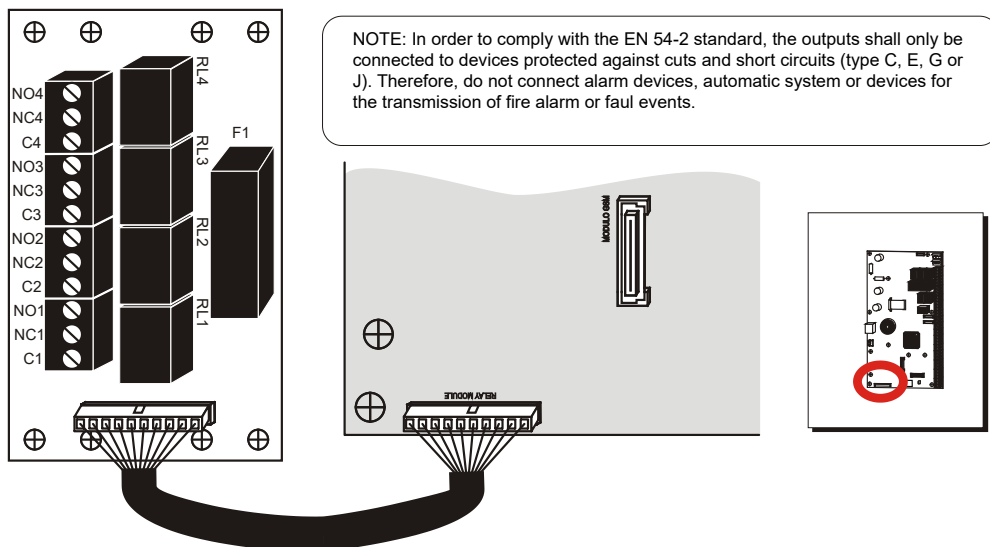

1. Use four self-tapping screws and washers to fix TAREL24 to the holes in the metallic housing.
2. Use the provided 10-wire cable to connect TAREL24's connector to the "Scheda rele" connector on the main board. The terminals on this board work just like the ones on the main board. By default, they all activate for the Fire event.



3.3.3 MDGSME/MD4GE

Warning: do not turn the control panel on while MDGSME/MD4GE is in place but the antenna is not connected.

1. Prepare a GSM / LTE 4G SIM card by inserting it in a mobile phone to disable the PIN code request and other accessory services.
2. Insert the SIM card in the SIM tray under the MDGSME/MD4GE board:

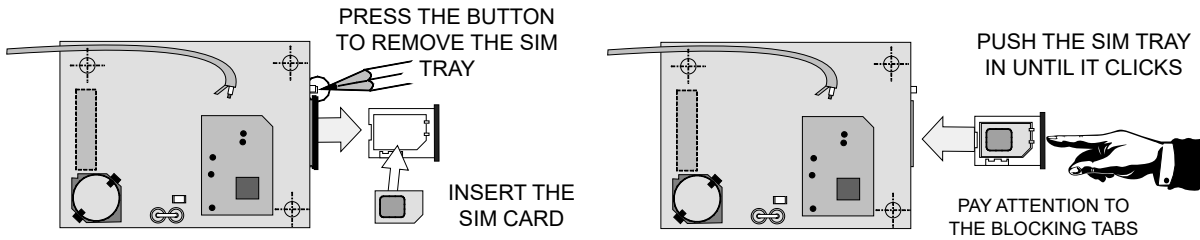

3. Insert the provided plastic spacers under the board, through the holes; have them click in.
4. Place MDGSME/MD4GE over the main board where shown below. Align the connector under the MDGSME/MD4GE board to the “modulo GSM” connector on the main board and the spacers to the holes there. Push down gently to the end and have the spacers click in.

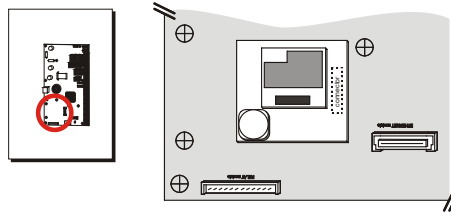

5. Install the antenna, provided as part of the GSMACI/ANT4GTA kit (pictured: TA2000 and GSMACI).
 - A. Remove the plastic cap on the top side of the control panel.
 - B. Assemble the kit (antenna cable connector, L-shaped bracket and large nut) using two 13 mm spanners.
 - C. Screw the antenna in the antenna cable connector.



TA1002 and TA1004:

- D. Slot the protection grommet up the hole on the top side of the control panel. Push the first ridge past the hole.
- E. Use the self-tapping screws to fix the kit in place.

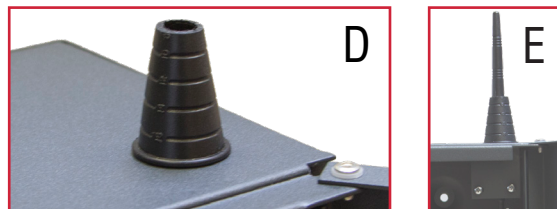

TA2000 and TA4000:

- D. Remove the screw right above the “Evacuate” button in the display flap.
- E. Use the bolt and nut to fix the kit in place. Use the self-tapping screws to prevent pivoting around the bolt.
- F. When turning the flap up, place the protection grommet around the base of the antenna.

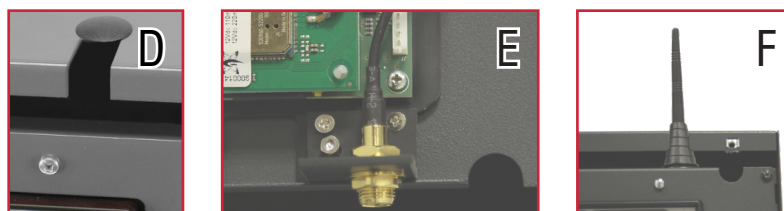

Alternatives to this antenna kit for when the GSM / LTE 4G signal around the control panel is weak are presented in the manuals for the extension cord kits GSMEXA2, GSMEXA15, ANT4GEXA2 and ANT4GEXA15 (extension kits are not EN-54 compliant).

6. Stick the provided CPR label next to the one of the control panel, on the right side of the container, and mark the MDLAN box on the label if the MDLAN module is installed.



3.3.4 TAEXP10 (TA2000 only)

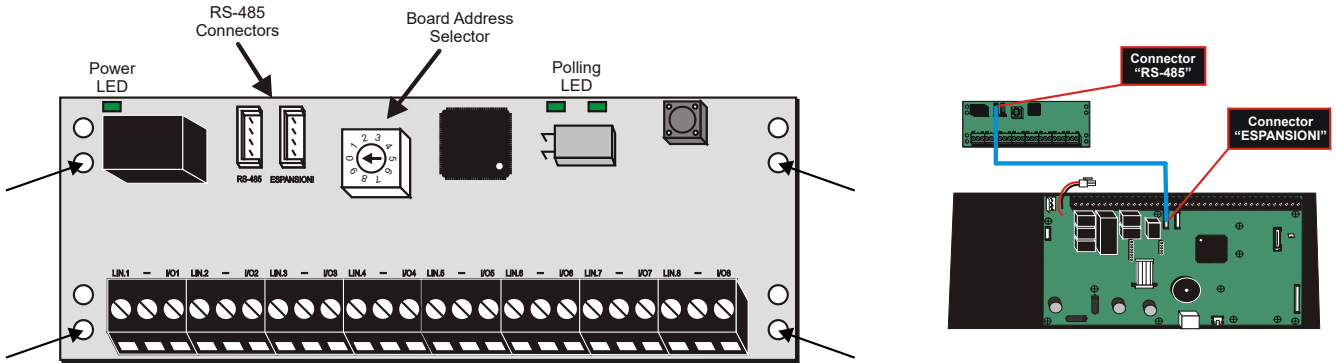

1. Insert the provided plastic spacers under the board, on the holes marked by the arrows (above); have them click in.
 2. Place TAEXP10 in the control panel where shown in the two images on page 3. Align the spacers to the holes there and have them click in.
 3. Use the provided 4-wire cable to connect TAEXP10's "RS-485" connector to the "Espansioni" connector on the main board.
 4. Make sure that the rotary switch is set to 0.
- The terminals on this board work just like the ones on the main board. Terminals lin1 to lin8 are assigned to zones 5 to 12.

3.3.5 LOOP MODULE

3.3.5.1 Installing a single loop module (on TA2000 or TA4000)

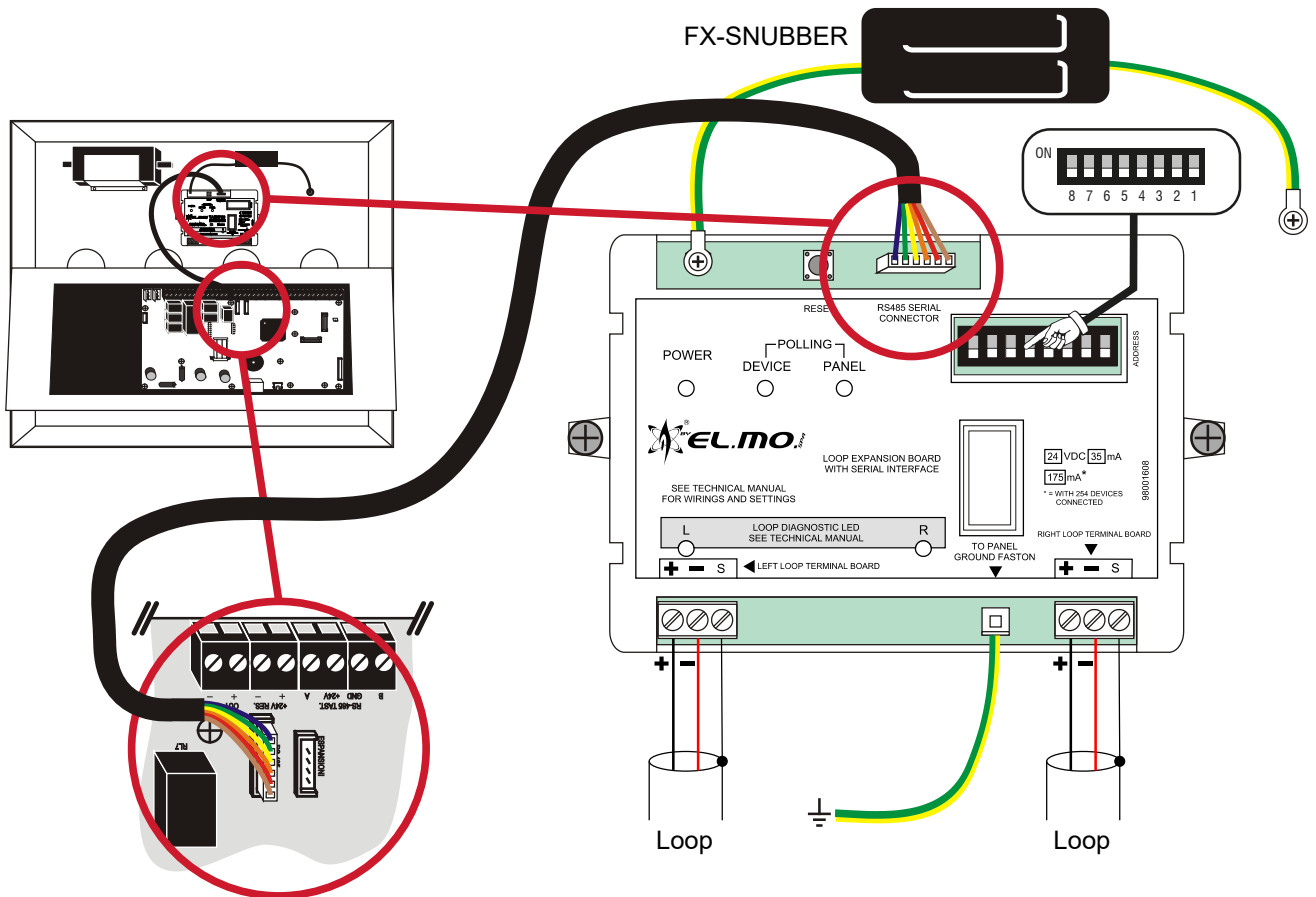

1. Use two self-tapping screws and washers to fix the module to the holes in the metallic housing.
2. Use two self-tapping screws and washers to connect FX-SNUBBER to the loop module (as shown) and to the screw soldered to the housing bottom.
3. Stitch FX-SNUBBER to the housing with two-sided adhesive tape.
4. Use the provided 6-wire cable to connect the loop module's "RS485" connector to the "RS-485" connector on the main board.
5. Use the provided 150 mm wire with a female faston to connect the male faston to the Ground screw terminal of the control panel.
6. Wire the two ends of the loop to the terminal boards (as shown), using the S terminals for the cable screen.
7. Leave all the dip switches OFF



3.3.5.2 Installing two loop modules (on TA4000)

1. Use four self-tapping screws and washers to fix both loop modules to the holes in the metallic housing. The right screw of the left module must also keep one cable lug of an FX-SNUBBER filter pressed between the module and the metallic housing.
2. Use three self-tapping screws and washers to connect the remaining cable lugs of the FX-SNUBBER filters to each loop module (as shown in the frame below) and to the housing.
3. Stitch both FX-SNUBBERS to the housing with two-sided adhesive tape.
4. Use one provided 6-wire cable to connect one loop module's "RS485" connector to the "RS-485" connector on the main board.
5. Use the other 6-wire cable to connect the other loop module's "RS485" connector to the "Espansioni" connector on the main board.
6. Use the provided 150 mm wires with a female faston to connect the male fastons on both modules to the Ground screw terminal of the control panel.
7. Use the provided 2-wire cable to connect the two modules together (as shown).
8. Wire the two ends of the loop to the terminal boards (as shown), using the S terminals for the cable screen.

9. Set the dip switches as shown below.
 - Left module: dip 1 ON and, if using the SYNC cable, dip 7 ON
 - Right module: all dials OFF
 MIEXP254 can only be the right module.

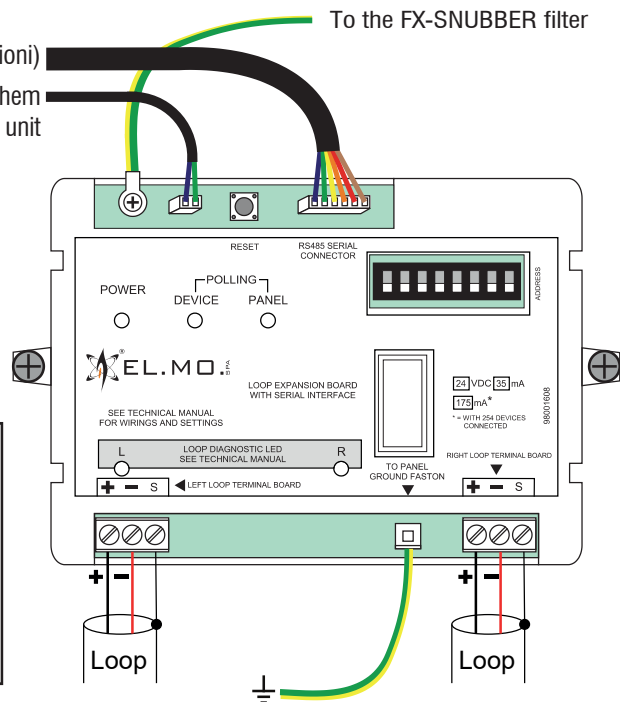
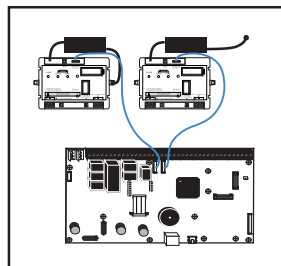

3.3.5.3 Example of device connection to a FYRA loop (TALOOP module with the FYRA logo)

The following diagrams show how to connect the loop cables to various devices available for the FYRA loop. To be able to correctly apprehend the devices on the loop, have at least the end of line resistor R (shown in the diagrams) connected to each supervised input or output. The value of R is specific to each device and it is described in its technical manual, together with any additional connection needed (e.g. power supply, lines to sounders, LEDs and detectors). For instance, MD110 can manage 1 Input line and 1 Output line; MD1P fully manages 1 set of Door retention magnets .

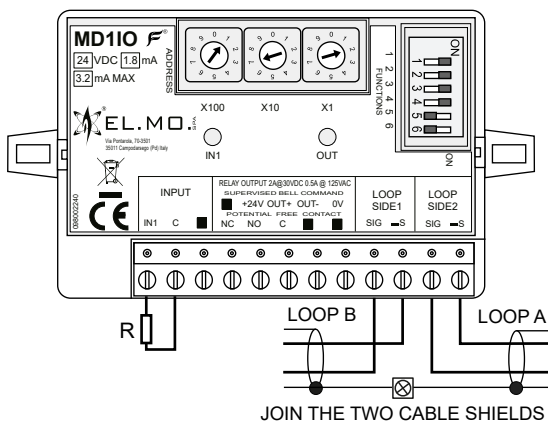

MD110

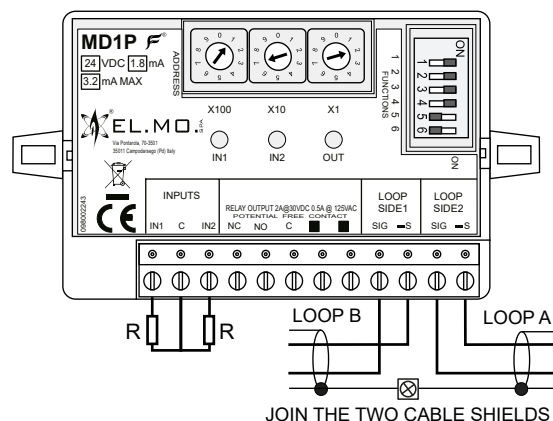

MD1P



MD2P and MD4IO are used to connect conventional devices to the loop.
 For instance, MD4IO can manage 4 Input lines and 4 Output lines; MD2P manages 2 sets of Door retention magnets.

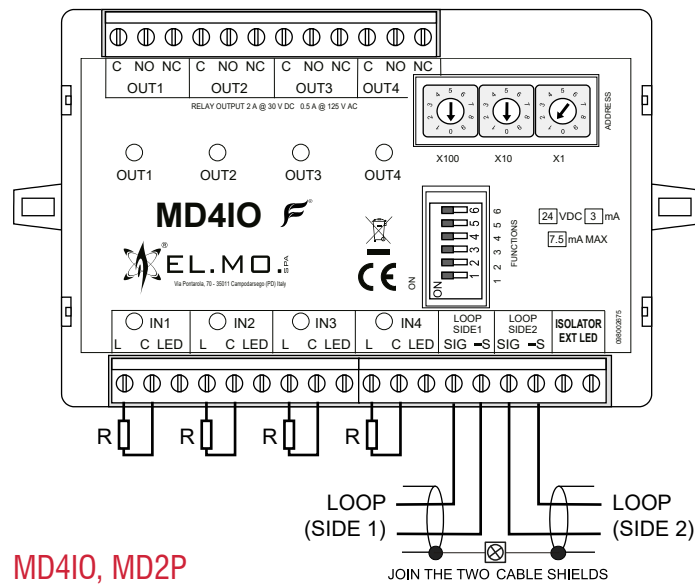

MD4IO, MD2P

The LSOUND sounder is a stand-alone loop device. The BSOUND sounder can be installed under a SNIxxA detector or on its own, with a plastic cover. If it is installed on its own, connect it like if it was an LSOUND.

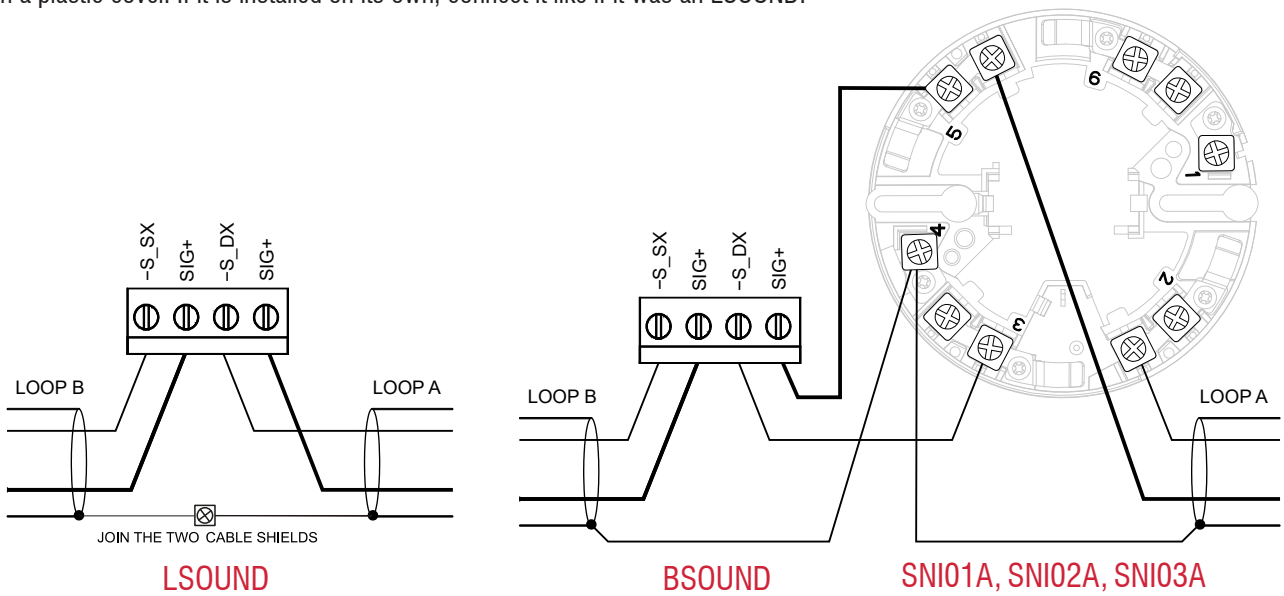

PAR is a resettable manual call point with an integrated isolator.

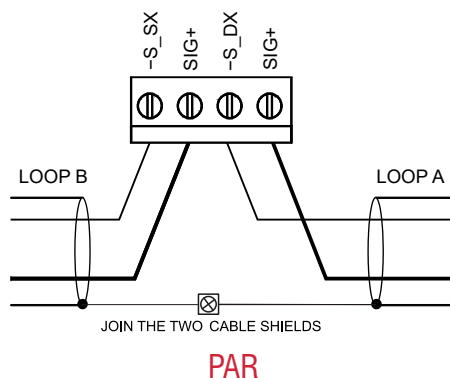



Most devices on the loop have an **address**, a code number from 1 to 254 that must be unique to that device.

- The address can be set in decimal notation via rotary switches (the rightmost switch for units, the leftmost for hundreds when holding the device so that the writings on the label are straight) or in binary code via dip switches (see the device manual).
- Some devices occupy extra addresses, consecutive to the one set on the switches (e.g. 4140ASBOX occupies 8 addresses, the one that has been set and the next 7). Make it so the extra addresses don't overlap with the addresses of other devices and they don't go out of the 1 ÷ 254 range. All addresses on the same physical device have to belong to the same zone.

We strongly suggest writing down which address(es) have been set on each device.

3.4 Battery connection

Use batteries appropriate to your control unit. TA1002 and TA1004: 2×7 Ah; TA2000: 2×7 Ah or 2×18 Ah; TA4000: 2×26 Ah.

Connect one pair of red/black cables to the terminals of one battery and the other pair to the terminals of the other battery.

TA1002, TA1004 and TA2000 use a 5 A fuse; TA4000 uses a 6.3 A fuse.

Have the provided NTCs touch the batteries and fix them in place with tape. Connect them to the main board as shown below.

Check the proper insulation of the connectors before powering up the control panel.

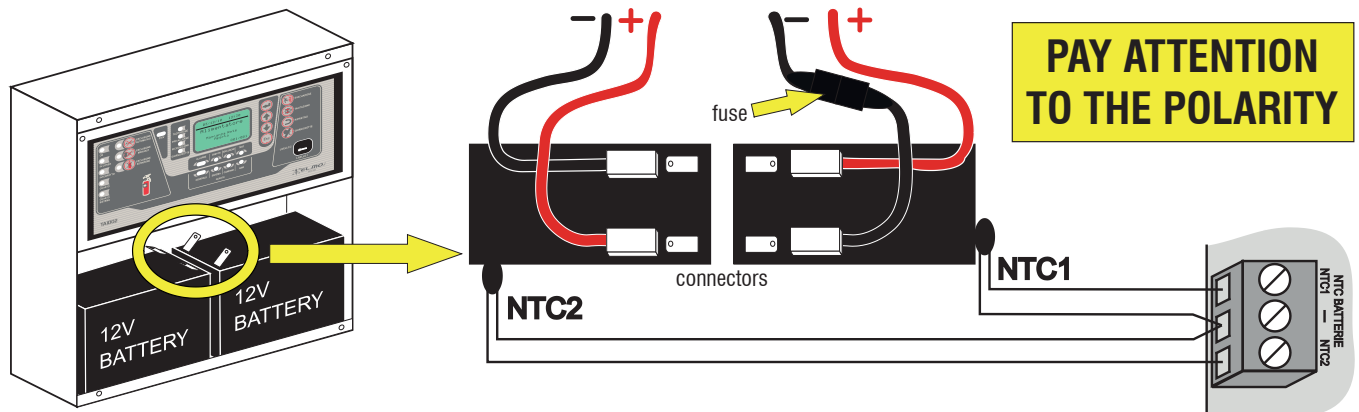



4. KEYBOARD PROGRAMMING

Insert and turn the provided plastic key in the keyhole near to the front display to access the user menus (LEVEL 2). If any alarm is displayed (the display backlight is red), press ESC. The display backlight is now white.

To enter a menu, press **↑** and **↓** to move the black selection bar over the desired entry, then press ENTER (↵). Press ESC to go back a step.
In this chapter, “LEVEL 3 ► MENU ► SUBMENU” means “from the root menu for level 3, enter MENU, then enter SUBMENU”.

LEVEL 2 ► **PROGRAMMING** (“PROGRAMMAZIONE”)*
Insert the default password (0000)

Whenever prompted to populate a string of numbers or text, use **↑** and **↓** to rotate through characters, use ENTER (↵) to confirm a character and to start editing the next one (if there is one) or to confirm the whole string when you reach its end.

If you don't press any button for 5 minutes, the control panel will automatically go back to level 2.

LEVEL 3 ► **SETTINGS** (“IMPOSTAZIONI”) ► LANGUAGE (“LINGUA”)
Use **↑** and **↓** to select English, then press ENTER.

From the settings menu you can also:

- Set a user code to access level 2 without having to use the plastic key.
- Set the time and date. The control panel uses the DD/MM/YY notation.
- Change the default LEVEL 3 password and add two different, 4-digit ones, setting a different username for each.
- Set up several time slot patterns, 8 different sounder patterns and 40 different zone groups. These settings are only referenced in some advanced functions that are passingly mentioned in this guide and fully detailed in the programming manual.
- Enter LEVEL 3 ► SETTINGS ► OPTIONS in order to:
 - Choose if a Ground fault generates the corresponding Fault event (shown on display and assignable to output devices) or not.
 - Choose the text shown in the three rows of the LEVEL 1 screen.
 - Choose how many minutes any mains fault or a battery fault needs to last before the corresponding Fault event is generated.
 - Choose the duration of the activation of the outputs that activate on control panel reset, expressed in seconds.

The LEVEL 3 ► ZONES menu only shows the zones that have devices assigned to them. While devices connected to conventional lines are automatically assigned to the zone of that line, devices on the loop have to be learned and programmed first:

LEVEL 3 ► **LOOP** ► SELF-LEARNING

- The General Fault LED blinks while the software memorizes the list of all correctly connected, addressed and powered devices in the loop. Previously memorized data is erased. If the procedure fails, find and correct the cause, then repeat the procedure.
- The number of devices found, divided by type, is displayed. Ionization smoke detectors are counted as gas detectors.
- Browse the list using **↑** and **↓**, compare to the real numbers, then press ENTER.
 - If all devices have been correctly learnt, choose YES and press ENTER to save.
 - Otherwise, choose NO and press ENTER to quit the procedure without saving.

LEVEL 3 ► LOOP ► DEVICES PROG.

Press ENTER to choose an address, then again to visualize the menu for that address. The available entries depend on the device.

- Assign a zone to each address. Assign the same zone to addresses belonging to the same device.
- Set a DESCRIPTION for the address, this will be displayed in alarm and fault messages for easily locating the device.
- Make sure that gas sensors and ionization smoke detectors have the right TYPE.
- Set the SENSITIVITY ► STANDARD THRESHOLD for detectors. The available values are Low, Middle and High.
- Choose which event is generated by the control panel when an input device goes into alarm (GENERATED EVENT) or which event activates an output device (ACTIVATION EVENT). The complete list of events is available in the programming manual.

LEVEL 3 ► **ZONES**

Enter a zone. The entries available depend on the device.

- Set a DESCRIPTION for the zone, this will be displayed in alarm and fault messages for easily locating the device.
- Set the SENSOR INPUT ► GENERATED EVENT for the conventional lines. This is the event generated by the control panel when an input device on the line goes into alarm. Events other than FIRE do not comply with the EN 54 standard.
- These menus also include TAREL24 relay outputs. The menu for relay # (1 to 4) is LEVEL 3 ► ZONES ► ZONE# ► OUTPUT LINE.
 - Set the ACTIVATION EVENT that activates the relay.
 - If you want the relay to be usually powered and to become idle when the activation event happens, set INVERTED to yes.

*A factory default resets the language to Italian: this guide provides Italian menu entry names up to the language menu.

LEVEL 3 ► **PANEL OUTPUTS** ► AUX# ► ACTIVATION EVENT

- Set the ACTIVATION EVENT that activates each AUX relay. AUX2 can not be set if the EXTING module is used.

LEVEL 3 ► **GSM** ► SETTINGS

- Browse to the PHONE NUMBER 1-8 entry and list up to 8 telephone numbers. All GSM / LTE 4G functions explained here reference these telephone numbers.
- Browse to the FIRE BRIGADE entry and activate all of the 1-8 numbers that correspond to Fire Brigade telephone numbers (a X mark appears near to any activated number). These numbers will have remote access to the control unit.

The remaining entries in the settings menu can be used to manage several other functions, e.g. re-routing messages received by the GSM / LTE 4G module, checks on the remaining credit, sending multiple copies of each message or specific sending conditions and delays.

LEVEL 3 ► GSM ► EVENT MANAGER

Choose which events will cause the GSM / LTE 4G module to send an SMS message. For each, set the telephone numbers targeted in the CALL NUMBER sub-menu (a X mark appears near any activated numbers) and select 9 from the MESSAGE sub-menu (standard SMS content).

LEVEL 3 ► **EXTINGUISHING UNIT**

- The STOP FLOWING entry can be used to interrupt the emission of the extinguishing agent once it is started.

The remaining entries are described in the technical manual for the EXTING board. Their default values are fully operative.

4.1 Testing

After programming the control panel, we suggest testing it in order to find (and solve) any wiring or hardware problems. Press ESC while in the root menu for LEVEL 3 to go back to LEVEL 2.

LEVEL 2 ► **TEST** ► ZONE

Choose a zone and press ENTER to mark it with a X. While a zone is marked, any manually induced alarm on one of its devices activates the REL.ALL output for 10 seconds.

LEVEL 2 ► TEST ► OUTPUT / LOOP OUTPUT / LOOP BELLS

Choose an output and press ENTER to activate it. Press ENTER again to deactivate it. Pressing ESC exits from the whole menu and deactivates every entry of that menu.

LEVEL 2 ► TEST ► DISPLAY / LED / BUZZER

These tests just activate the corresponding element for a set time:

- The display pixels light up one column at a time while the retro-illumination changes through all four possible colours.
- All LEDs light up for around 2 seconds.
- The buzzer turns on for around 5 seconds.

5. PC PROGRAMMING

The BROWSERONE software used to program the control panel runs on Windows 7, 8 or 10.

Download the installation files from the product page of BROWSERONE at www.elmospa.com

1. If this is the first time installing BROWSERONE, run *BrowserOne_x.x.xx_web.exe*
If BROWSERONE is already installed, run *BrowserOne_x.x.xx_update.exe* instead.
Follow the instructions displayed on screen, ignoring the system alerts about software non-compliance.
2. Install the TACÓRA module: *Tacora x.x.x_setup.exe*
3. Once installation ends, open BROWSERONE from its desktop icon.
4. If BROWSERONE ENTERPRISE has been activated, the default username is "admin". Leave the password field empty, login and close the following dialog.
5. Open MODULES ► LOAD MODULE, select the TACÓRA module and press OK to load it.
Beginning with the next time you use BROWSERONE, it will be possible to load the module directly from the MODULES menu.
6. Power up the control panel, then use a CP8/SER2 cable to connect the mini-Din port on its main board (p. 15) to the PC.
7. Open CONNECT ► DETECT PANELS, select the proper port and press "Connect to the panel...". Press OK in the next pop-up.
8. The program prompts for the insertion of the LEVEL 3 password. If the passwords have never been changed, just press OK.
9. IMPORTANT: Run ACTIONS ► READ SETUP to load the configuration of the panel. Wait for the ACTIONS menu to be available again.
10. Modify any setting (see the *software guide*), then use ACTIONS ► WRITE SETUP to save the modified configuration to the panel.
11. When the ACTIONS menu is available again, use CONNECT ► CLOSE CONNECTION before physically disconnecting the cable.



6. LED MEANING

Undesirable conditions (to correct for a proper functioning) have a grey background.

	LED name	Colour	OFF	Blinking	ON
TAXP10	Power	Green	No power	---	Power OK
	Polling	Green	No communication to the panel	Communication OK	---
Loop module	Power	Green	No power	---	Power OK
	Polling device	Green	No communication to devices	Communication OK	---
	Polling panel	Yellow	No communication to the panel	Communication OK	---
	L	Yellow	L line short circuited	Loop open	OK
	R	Yellow	R line short circuited		
TACÓRA FRONT PANEL	Power	Green	No power	---	230 V power OK
	Silence	Yellow	No silenced acoustic devices and no silenced buzzer	---	Acoustic devices / buzzer silenced
	Pre-alarm	Red	No prealarm	---	Pre-alarm ON
	Invest. delay	Yellow	No active countdowns	---	Countdown active
	Day / night	Yellow	Day / night mode inactive	---	Day / night mode active
	Fire	Red	No alarm	Alarm ON	Alarm ON (silenced sounder)
	GSM ON	Red	Telephone dialler OFF	Waiting for confirm.	Telephone dialler ON
	Disable	Yellow	All elements enabled	---	At least one disabled element
	Test	Yellow	No elements under test	---	Element(s) under test
	General fault	Yellow	No fault events	Fault events	Fault events (silenced sounder) or loop auto learning
	System fault	Yellow	CPU active	CPU fault	CPU fault (silenced sounder)
	Sounders fault/disabled	Yellow	Bells enabled	Bells fault	Bells disabled
	GSM fault/disabled	Yellow	GSM / LTE 4G enabled	GSM / LTE 4G fault	GSM / LTE 4G disabled
	EXTING FRONT PANEL	ON	Red	Idle module	Pre-activated
In progress		Red	No extinguishing flux	End of discharge	Presence of extinguishing flux
Blocked		Yellow	No emergency interruption	Emergency fault	Activation emergency extension
Fault		Yellow	No fault events	---	Fault events
System fault		Yellow	CPU active	---	CPU fault
Disable autom. mode		Yellow	Automatic requests enabled	---	Automatic requests disabled
Disable manual mode		Yellow	Manual requests enabled	---	Manual requests disabled
Disable exting		Yellow	Release output enabled	---	Release output disabled

7. CONNECTION TO E-CONNECT

With the e-Connect platform, users can monitor their fire and intrusion detection control units and installers can change the control units' settings with BrowserOne over the Internet, without having to visit the user. Visit e-connect.elmospa.com to discover all of its other powerful features and ask for a demo account at international@elmospa.com

- Access the e-Connect installer interface and create a new user.
 - Click on the new user, then on the Actions Menu and on Generate Key.
- Install the MDGSME, MD4GE or MDLAN module.
- Access the installer menu of the control unit and configure the module from the **GSM** or **Ethernet** menu.
- Access the **Internet Account** menu.
 - Activate e-Connect by selecting the **Enable over Ethernet/GPRS** entry specific to the chosen module.
 - Input the registration code from the Generate Key button e-mail in the **Register** menu entry.

Further instructions and troubleshooting are available in the programming manual.

















8. DIAGNOSTICS

TROUBLE MESSAGE	WHAT TO DO
“ZXXX Sensor Input Short” “Z000 Manual Call Point Short”	If a conventional (1–4) or MCP (0) zone has no 4700 Ω EoL resistor, install it and reset the control unit. If the resistor is installed, disconnect the line at the terminals* and measure the resistance between them: <ul style="list-style-type: none"> • $\sim 0 \Omega$ = short circuit (find and fix the fault) • resistance tends to infinite = open circuit (find and fix the fault) • far from 4700 Ω = wrong wiring or the EoL resistor is too big / too small. • $\sim 4700 \Omega$ = try connecting the EoL resistor directly to the terminals: <ul style="list-style-type: none"> • the error persists = input fault (have the main board repaired) • the error is solved = look for problems in the line.
“ZXXX Sensor Input Open” “Z000 Manual Call Point Open”	
“ZXXX Digital I/O Short”	These messages refer to the balanced lines that use the I/O programmable terminals.
“ZXXX Digital I/O Open”	Act like described above for conventional and MCP lines, but use a 47,000 Ω EoL resistor instead.
Loop not registered	Error message displayed at start-up if the loop module has been installed and is not programmed yet. Run the auto-learning process (programming manual), save and reset the control unit.
Loop No Answer	Loss of communication between the control unit and an acquired loop module. Verify the connection between the module and the main board and between the module and the loop. Check the signalling LEDs of the module, described in its technical manual. If no problems are immediately noticeable: disconnect the loop from the module*, wire a single device in its place and run the auto-learning procedure; if the error disappears, the problem is on the loop. If a loop module is not working, but a different loop module or an EXTING module correctly work, the problem lies in the module or in the loop; if all these modules stop working at once, the problem lies in the main board or in the RS-485 line.
Loop short circuit	Verify the loop module LEDs for confirmation. Disconnect the loop from the module*, wire a single device in its place and run the auto-learning procedure; if the error disappears, the problem is on the loop.
Short earth-gnd	Check the wirings. Self-solving fault, it can persist for around one minute at the first start-up. PC connection can cause an earth-gnd fault that will solve on its own at the end of the connection.
Extinguish No Data	Check the two LEDs on the EXTING module. <ul style="list-style-type: none"> • If both are on, reset the control unit. • If both are off, disconnect and reconnect the module*. If the problem persists, verify the functioning of loop modules (if installed): <ul style="list-style-type: none"> • If they work correctly, the problem lies in the module or in the loop. • If all these modules stop working at once, the problem lies in the main board or in the RS-485 line.
Extinguish No 24V power supply	The EXTING module detects a tension of less than 24 Vdc. Verify the correct functioning of the power supply and the good condition of the batteries, both at the control unit and at the remote power supply units.
Extinguish ... No/Short/Open ...	These messages refer to the balanced lines of the EXTING module. Act like described above for conventional and MCP lines, using a 47 k Ω EoL resistor for the “pressure switch” (<i>manostat</i>), “valve output” (<i>solenoid valve</i>), “ext. man. input” (<i>external manual input</i>) and “stop input” terminals; a 4700 Ω one for the “release input” and “sounder output” terminals.
Extinguish Low Pressure	The manostat that monitors the tubes of the extinguishing system is registering a pressure drop. Check the tubes.
TA Repeater # No Answer	Try the following solutions, in this order: <ul style="list-style-type: none"> • Verify that the address of the panels is 1 and 2 (just 1 if using a single panel), then reset the control unit. • Verify that the panels are correctly connected and powered. • Disconnect the panel and wire it near to the control unit to exclude line problems, then reset the control unit. • Replace the panel. If the problem persists, have the main board repaired.
Sounder Open Sounder Short	These messages refer to the RELÈ ALLARME (<i>alarm relay</i>) balanced line. Act like described above for conventional and MCP lines.
Power Supply 24V Output	There is no power output at the OUT +24V terminals. Disconnect any loads and verify the power output at the terminals. If the power output is working, look for short circuits or over-absorptions. If the power output is not working, it is a main board fault. (Self-solving fault.)
Power Supply Resettable 24V Output	There is no power output at the +24RST terminals. Act like described for the OUT +24V terminals.
No Syncro	The synchronization cable connecting two loop modules is damaged or missing, or dip switch 7 of both modules is set to ON (one has to be set to OFF).
Fault Syncro	The synchronization signal is irregular. Check that the synchronization cable connecting the loop modules is undamaged and that its wires don't touch each other.

*after disconnecting the power sources, batteries included



9. OPERATOR INSTRUCTIONS

<p>Control panel mode Alarm mode -Optical-acoustic devices active -Red display backlight -Alarm LED blinking -Buzzer ON</p>	<p>Press  to switch off the buzzer. To switch off optical-acoustic devices: Insert and turn the key counterclockwise or type  [][][] to access level 2. Press  . Alarm LED will switch from blinking to fixed. To view all alarm messages: Turn the key clockwise or press  (depending on how you accessed level 2) to return to level 1. Use ↑ and ↓ to view previous/next message. Once the conditions that generated the alarm stop: Run a reset procedure.</p>
<p>Acknowledgement/Investigation -Red display backlight -pre-alarm and investigation LEDs ON -Buzzer ON -Countdown on screen</p>	<p>Insert and turn the key counterclockwise or type  [][][] to access level 2. Press  . Press  within the first timer interval. Press  to switch off the buzzer. Investigate the affected area to check that it is not a false alarm. To cancel the alarm: Go back to the control panel and run a reset procedure before the second timer expires. To confirm the alarm: Run the evacuation procedure or let any timer end.</p>
<p>Control panel mode Fault -Yellow display backlight -At least one fault LED blinking -Buzzer ON</p>	<p>Press  to switch off the buzzer. The general fault LED will switch to fixed light. Run a reset procedure. If the faults keep being reported: Press  to switch off the buzzer. Use ↑ and ↓ to view all fault messages. Signal the faults to an authorised maintenance engineer. Follow his/her instructions and organise a repair service.</p>
<p>Reset procedure</p>	<p>Procedure used to stop the acknowledgement/investigation countdown and to cancel existing maintenance requests and alarm and fault events. Insert and turn the key counterclockwise or type  [][][] to access level 2. Press  .</p>
<p>Evacuation procedure</p>	<p>Procedure used to enter the alarm status manually. Insert and turn the key counterclockwise or type  [][][] to access level 2. Press  .</p>



10. EC DECLARATION OF PERFORMANCE

0051-CPR-0402

CERTIFICATO DI COSTANZA DELLE PRESTAZIONI



ALLEGATO / ANNEX

No. 1 Alarm transmission and fault warning routing equipment board type MDL/AN, used with or without the board type MDG/ME or MDGE...

- Technical Characteristics:
- Maximum number of detection and/or manual call points: 96 (32 for each zone)
- Maximum number of detection of the microcontroller used on the CPU board: 100 (PC232/8/BD) 44

0051-CPR-0402

CERTIFICATO DI COSTANZA DELLE PRESTAZIONI



ALLEGATO / ANNEX

Modello TA1002 comprende un involucro metallico con grado di protezione IP30, contenente:
- N.1 Scheda CPU
- N.1 Alimentatore marca ELMO, modello AL25W24 da 29V - 2 A, oppure...

- Caratteristiche tecniche / Technical characteristics:
- Numero massimo di zone: 3
- Numero massimo di sensori o punti manuali: 96 (32 per ogni zona)
- Identificazione hardware del microcontrollore usato sulla scheda CPU: NIP - LPC2378/8BD/144

0051-CPR-0402



CERTIFICATO DI COSTANZA DELLE PRESTAZIONI

In conformità di Regolamento (UE) n. 305/2011 del Parlamento Europeo e del Consiglio del 9 marzo 2011...

Controllo di controllo e di segnalazione con apparecchiatura di alimentazione integrata

Elementi di tipo / Type reference: TA1002
Marca commerciale / Trademark: ELMO
Cellulo da / Produced by: ELMO S.p.A. Via Fontazzo 70 - 35011 Campodarsego (PD) - Italy

Questo certificato attesta che tutte le disposizioni (quarantamila la valutazione e la verifica della costanza della prestazione e le prestazioni descritte nell'Allegato ZA della norma...

EN 54-2:1997 + A1:2006; EN 54-4:1997 + A1:2002 + A2:2006
nell'ambito del Sistema 1 per le prestazioni specificate in questo certificato sono applicate e che il sistema di controllo della produzione eseguito dal fabbricante è stato verificato in maniera da assicurare la costanza delle prestazioni...

EMISIORE CONFORME / CURRENT ISSUE: 11/03/2024
RIVOLTOE / REVISION: 2

Questo certificato non ha alcun valore se non è accompagnato dal foglio di identificazione del prodotto (IDP) e il nuovo foglio deve essere emesso...

Organismo notificato / Notified body: / No. 001
Questo certificato è soggetto al Regolamento europeo in materia di certificazione del prodotto...

IMQ S.p.A. - con Socio Unico | Via Quintiers 43 | 35013 Marone | www.imq.it

ACCREDIA PRD N° 0005PRD

Immagini: 3 di 3



DICHIARAZIONE DI CONFORMITÀ UE CE EU DECLARATION OF CONFORMITY

N° 0051-CPR-0402

EL.MO. S.p.a con Socio Unico dichiara sotto la propria responsabilità che il prodotto / declares that the product: TA1002

Centrale di controllo e segnalazione incendio / Control and indicating Panel for Fire detection

al quale questa dichiarazione di conformità e prestazione (DoP) si riferisce, è conforme alle seguenti norme: to which this declaration of conformity and performance (DoP) is referred with the following:

Table with 2 columns: Standard (e.g., EN 50130-2011, EN 61000-6-3:2007) and Description of requirements.

e quindi rispondente ai requisiti essenziali delle direttive: and then in accordance with the following directives:

Table with 2 columns: Directive (e.g., 2014/50/UE, 2011/65/UE) and Description of essential requirements.

Pagina/Page 1 di 2



DICHIARAZIONE DI PRESTAZIONE (DoP) / DECLARATION OF PERFORMANCE (DoP) Sistema/System 1

Table with 4 columns: Performance, Specific technical harmonized, and Notes. Rows include: Prestazione di alimentazione, Affidabilità operativa, Durabilità dell'affidabilità funzionale, etc.

Campodarsego 24/05/2024

Consigliere Delegato EL.MO. S.p.A. Ing. Salvatore Pastorella

Pagina/Page 2 di 2



11. CONTENTS

1. GENERAL FUNCTIONING.....	3
2. POSITIONING THE CONTROL PANEL.....	3
3. INSTALLATION.....	4
3.1 Main board: connectors and jumpers.....	5
3.2 Wiring.....	6
3.2.1 Input lines.....	6
3.2.1.1 MCP line (zone 0).....	6
3.2.1.2 Conventional lines (zones 1 to 4, plus zones 5 to 12 on the TAEXP10 board).....	6
3.2.2 Output lines.....	7
3.2.2.1 OUT +24V line.....	7
3.2.2.2 +24V RES. line.....	7
3.2.2.3 Relay lines (prealarm, fault, AUX1, AUX2 and TAREL24 outputs).....	7
3.2.2.4 Alarm line.....	7
3.3 Connection of the optional boards.....	8
3.3.1 EXTING.....	8
3.3.1.1 Call point lines.....	8
3.3.1.2 Pressure input.....	9
3.3.1.3 Electro-valve output.....	9
3.3.1.4 Alert outputs.....	9
3.3.2 TAREL24.....	9
3.3.3 MDGSME.....	10
3.3.4 TAEXP10 (TA2000 only).....	11
3.3.5 LOOP MODULE.....	11
3.3.5.1 Installing a single loop module (on TA2000 or TA4000).....	11
3.3.5.2 Installing two loop modules (on TA4000).....	12
3.3.5.3 Example of device connection to an AS loop (TAEXP20 module).....	12
3.4 Battery connection.....	14
4. KEYBOARD PROGRAMMING.....	15
4.1 Testing.....	16
5. PC PROGRAMMING.....	16
6. LED MEANING.....	17
7. CONNECTION TO E-CONNECT.....	17
8. DIAGNOSTICS.....	18
9. OPERATOR INSTRUCTIONS.....	19
10. EC DECLARATION OF PERFORMANCE.....	20
11. CONTENTS.....	24

DOWNLOAD SOFTWARE AND TECHNICAL DOCUMENTATION

TA1002

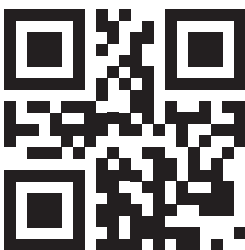

goo.gl/kVyFTP

TA1004

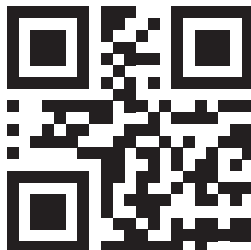

goo.gl/RU1gCC

TA2000

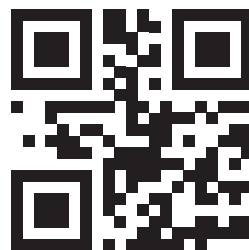

goo.gl/wq6efQ

TA4000



goo.gl/WNRJUC

TACÓRA series - Control panels and signalling equipment with integrated power supply device
QUICK GUIDE - December 2024 edition

090011106

The information and product features herein are not binding and may be changed without prior notice.

EL.MO. Spa Via Pontarola, 70 - 35011 Campodarsego (PD) - Italy

Tel. +390499203333 - Fax +390499200306 - Technical Ass. +390499200426 - www.elmospa.com - international@elmospa.com